

RB900-Pro

USER MANUAL



GSM / LTE



ENGLISH VERSION

1. Overview	4
2. References	5
3. Package	6
3.1 Box	6
4. Complete package contents	7
5. General presentation	8
5.1 Product pictures	8
5.2 External connections	9
5.2.1 GSM antenna connector	9
5.2.2 Bluetooth antenna connector	10
5.2.3 RS-232 Interface (EIA574)	11
5.2.4 Power supply connector	12
5.2.5 SIM card holder	13
5.3 Product sticker	14
6. Basic features and services	15
7. Using the modem	16
7.1 Setting up the modem	16
7.2 Mounting the modem on the wall	16
7.3 Checking the communication with the modem	17
7.4 Status of the modem (LEDs)	17
7.5 Disabling and enabling echo function	18
7.6 Verifying the strength of received signal	19
7.7 PIN code status	19
7.8 Network registration	20
7.8.1 GSM network registration	20
7.9 GPRS network registration	21
7.10 AT commands summary	22
8. Troubleshooting	23
8.1 No connection/communication with the modem	23
8.2 Receiving ERROR message	23
8.3 Receiving NO CARRIER message	24
9. Technical characteristics	25
9.1 Mechanical characteristic	25
9.2 Housing description (dimensioning diagram)	25
10. Electrical characteristic	26
10.1 Power supply	26

10.2 RF characteristics	26
10.3 External antenna	27
10.4 Environmental characteristic	27
11. Safety recommendations	28
11.1 General Safety	28
11.2 Care and Maintenance	28
11.3 Responsibility	28
12. Conformity Assessment Issues	29
13. Safety Recommendations	30
14. List of Acronyms	31
15. On-line support	33

Overview

The RB900-Pro terminal is the complete modem solution for wireless m2m applications. Based on the high quality module, RB900-Pro offers high level GSM/UMTS/LTE Cat. 1, GPIO and optional Dual SIM, MIMO, 1-Wire, GNSS receiver and internal battery features in compact aluminum housing with all the standardized interfaces. Its small size and wide supply voltage range, make it easy to integrate into all kinds of machines.

The RB900-Pro modem series, offering e-mail, TCP/UDP data transmission, SMS and SMTP communication is a universal solution for all low-volume M2M and mobile data applications including metering, traffic systems, transportation and logistics, security, vending machines, and facility management.

The device can be controlled by standard AT commands or by customer's own application, thus making it the smallest, most complete SMT platform for m2m solutions.

This document contains a full description of the RB900-Pro modem and gives information about installation and use.

References

- [1] Quectel_EC25&EC21_AT_Commands_Manual_V1.1.pdf

Safety Recommendations

READ CAREFULLY

Be sure the use of this product is allowed in the country and in the environment required. The use of this product may be dangerous and has to be avoided in the following areas:

- where it can interfere with other electronic devices in environments such as hospitals, airports, aircrafts, etc
- where there is a risk of explosion such as gasoline stations, oil refineries, etc

It is responsibility of the user to enforce the country regulations and the specific environment regulations.

Do not dismantle the product; any sign of tampering will compromise the warranty validity.

We recommend following the instructions of the hardware user guides for the correct wiring of the product. The product has to be supplied with a stabilized voltage source and the wiring has to conform to the security and fire prevention regulations.

The product has to be handled with care, avoiding any contact with the pins because electrostatic discharges may damage the product itself. The same precautions have to be taken with the SIM, carefully check the instructions for its use. Do not insert or remove the SIM when the product is in power saving mode.

The system integrator is responsible of the functioning of the final product; therefore, care has to be taken of the external components of the module, as well as of any project or installation issue, because the risk of disturbing the GSM network or external devices or having impact on security. Should there be any doubt, please refer to the technical documentation and the regulations in force.

Every module has to be equipped with a proper antenna with specific parameters. The antenna has to be installed with care in order to avoid any interference with other electronic devices and has to guarantee a minimum distance from people (20 cm). In case of this requirement cannot be satisfied, the system integrator has to assess the final product against the SAR regulation.

Package

Box

On the original box, you will find the product sticker. It should match modem sticker on the device. This verifies that your modem is an original product. More information about stickers in Product sticker. Modem packaging dimensions are 21 x 13.5 x 70.

Complete package contents



Complete package contains:

- RB900-Pro terminal (item A)
- antenna (item B)
- power supply with 4-pin (item C)
- 2-pin GPIO cable 1,5m open end (item D)
- 1-pin GPIO cable 1,5m open end (item E)

General presentation

Product pictures

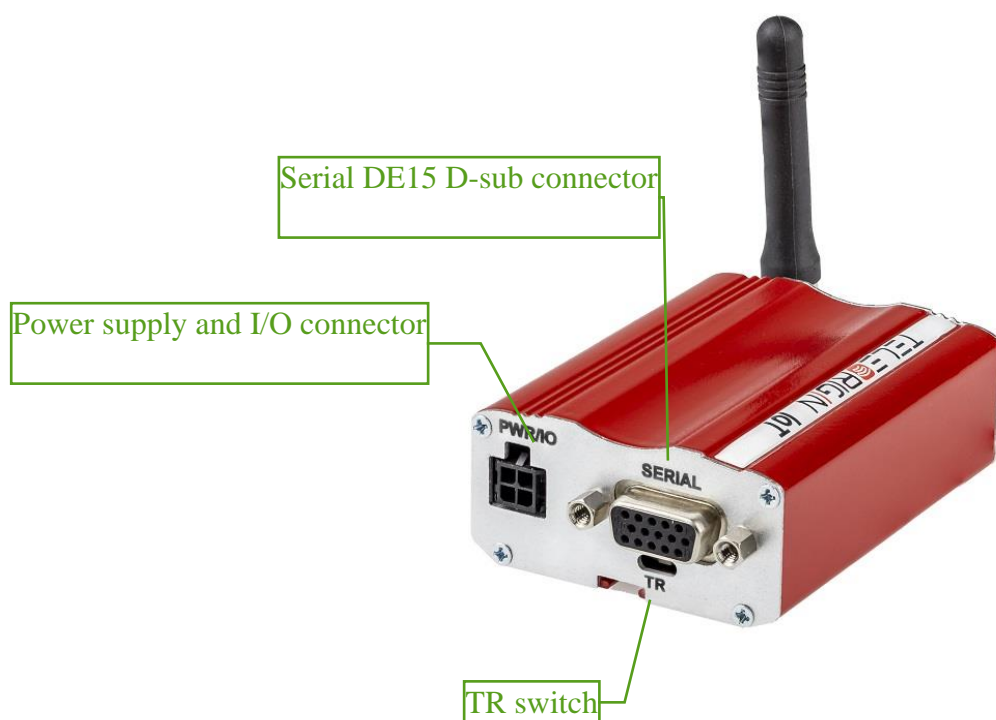
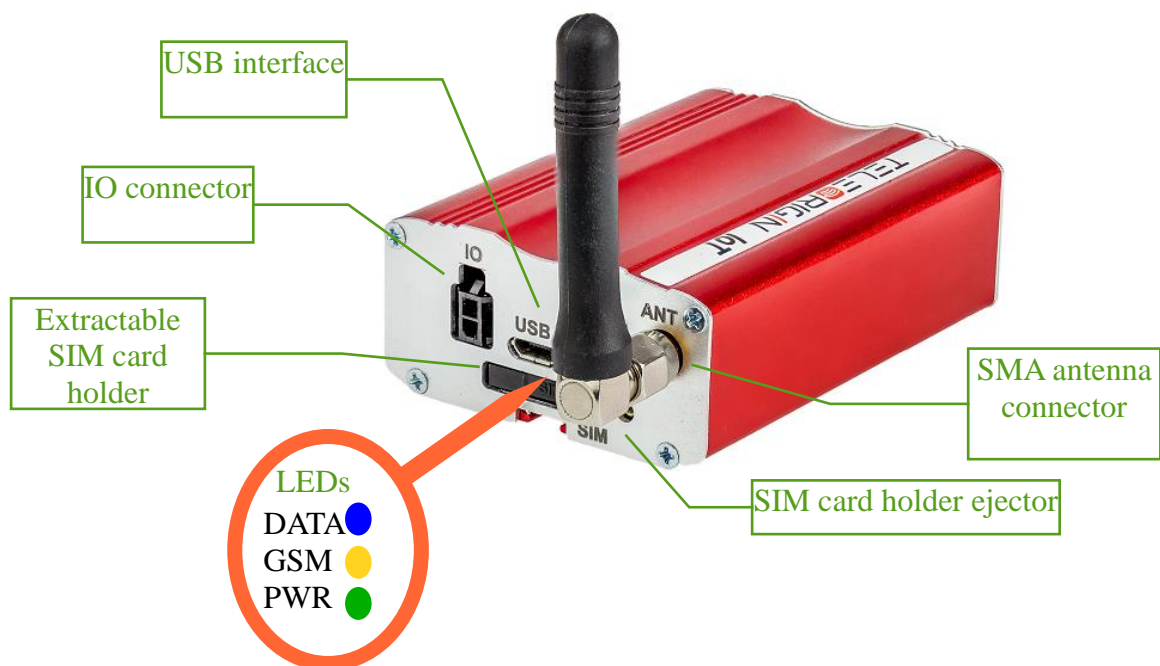

External connections

GSM antenna connector



An SMA antenna input is used to connect an external GSM antenna. To establish a connection with a GSM network, an external antenna must be used. Type of antenna depends on the GSM coverage. In good circumstances (level of received signal is high) use the antenna supplied in the package. If the range of GSM is low or none, an outdoor or indoor (for instance in a place where GSM range is sufficient) antenna should be used.

Note: *If there is no antenna connected to the SMA connector, connection with a GSM network is impossible.*

Note: *Make sure you don't tighten the antenna too much. The torque setting of SMA connector is 0.15 – 0.20 NM.*

GNSS antenna connector

Modem can be also equipped with GNSS antenna connector (optional) to connect external GNSS antenna.

Note: *Make sure you don't tighten the antenna too much. The torque setting of SMA connector is 0.15 – 0.20 NM.*

D-Sub 15-pin connector



The RB900-Pro terminal is equipped with a D-Sub DE15F 15-pin connector to control the RS232 interface, RS232 AUX/Debug/MCU/Modem (option) or RS485 Modem/MCU (option).

Table of DB9 pins:

Pin No.	Name	Dir	Description
1	DCD	IN	Data Carrier Detect
2	TxD	OUT	Transmit Data (a.k.a TX, Tx)
3	Boot		Modem boot. This signal must not be connected and must not be used. Function reserved for manufacturer or distributors only.
4	NC	-	-
5	NC	-	-
6	RxD	IN	Receive Data (a.k.a RX, Rx)
7	DSR	IN	Data Set Ready (optionally RS485 A)
8	DTR	OUT	Data Terminal Ready (optionally RS485 B)
9	GND	-	Ground
10	NC	-	-
11	CTS	OUT	Clear To Send
12	RTS	IN	Request To Send
13	RI	IN	Ring Indicator
14	Reset	IN	Modem reset
15	NC*	-	Not connected in standard version*

* - Analog Input 0, 0-10V as an option

Power supply and I/O connector

The power supply and I/O connector is a 4-pin Micro Fit connector for external DC power supply connection, which can handle voltage from range 5..30 V DC, 2.5 W max. continuous power and one output (OC) and one Input.



No.	Singal
1	Output 1 (OC)
2	Not connected in standard version*
3	GND
4	V+ DC

* - Opto Input 1 as an option

Attention!

Any attempt to power on the terminal from a DC source outside of the 5 to 30 V range may result in physical destruction of the device.

NOTE: If the internal battery option is present, removing power supply will not turn the terminal OFF.

GPIO connector

The GPIO connector is a 2-pin Micro Fit connector for digital inputs. Pinout:

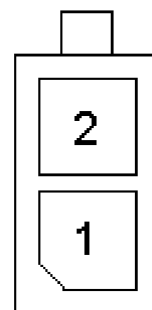

No.	Singal
1	GND*
2	1-Wire**

* Pin no. 1 on GPIO connector can be used as Opto Input 3 (option).

** Pin no. 2 can be used as Opto Input 2 or Analog Input 1 (option).

Possible GPIO configurations:

X - Without IO

option IO:

- 1 - Pin1 = DI Pin2 = GDN
- 2 - Pin1 = DI Pin2 = DI
- 3 - Pin1 = AI Pin2 = GDN
- 4 - Pin1 = AI Pin2 = DI
- 5 - Pin1 = modem 1 wire Pin2 = GDN
- 6 - Pin1 = modem 1 wire Pin2 = DI
- 7 - Pin1 = uP 1 wire Pin2 = DI
- 8 - Pin1 = uP 1 wire Pin2 = DI

LED behavior

The operational status of the RB900-Pro terminal is signaled by external LEDs placed on the front panel of the modem. The status of all modem LEDs is described in the table below.

LED	Color	Description
PWR	Green	Power supply
GSM	Yellow	Net status: Flicker slowly (200ms High/1800ms Low) - Network searching Flicker slowly (1800ms High/200ms Low) - Idle Flicker quickly (125ms High/125ms Low) - Data transfer is ongoing
DATA	Blue	GSM GPIO 2 – controlled by user with AT command: AT+QGPIOCFG=10,0,1,0,0 AT+QGPIO=0,10 AT+QGPIO=1,10,0 (LED OFF) AT+QGPIO=1,10,1 (LED ON)

SIM card holder

SIM card holder is placed at the front of the RB900-Pro terminal (as shown below) and is accessible externally. To insert a SIM card into the holder, press the **yellow button**, eject the little drawer, place the SIM card inside and reinsert the drawer into the modem (you will hear a “click”). To operate the module in a GSM network, it is necessary to insert a SIM card obtained from the network operator.



Product sticker

Product stickers are on the modem and on the product box. A production sticker includes the following information:

- product serial number (IMEI) and model signature
- manufacturer address
- the CE marking
- the 15-digit bar code (box sticker only)

Device sticker

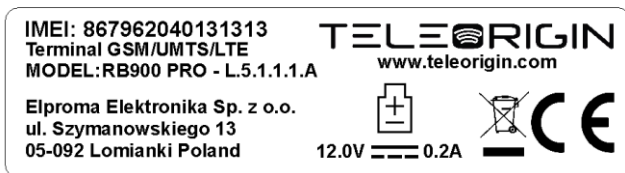

Box sticker



Basic features and services

Basic features and available services for the RB900-Pro are contained in the table below.

Feature/service	Description
Standard	Supported Bands: LTE Cat. 1: B1/B3/B5/B7/B8/B20 WCDMA: B1/B5/B8 GSM: Dual-band B3/B8 Physical: <ul style="list-style-type: none"> • 83 x 53,5 x 25 mm • Weight 89 g
Speed	LTE: Max. 10Mbps (Downlink) / Max. 5Mbps (Uplink) WCDMA: Max. 384Kbps (Downlink) / Max. 384Kbps (Uplink) EDGE: Max. 296Kbps (Downlink) / Max. 236.8Kbps (Uplink) GPRS: Max 107Kbps (Downlink) / Max. 85.6Kbps (Uplink)
Interfaces	<ul style="list-style-type: none"> • USB 2.0 with High Speed up to 480Mbps • RS232 on 15-pin D-Sub female connector • RS485 • GPIO • 1-Wire • OneWire (optional) • GNSS receiver (optional) • Internal battery (optional) Connectors <ul style="list-style-type: none"> • GSM/LTE SMA-Female • LTE Diversity SMA-Female (optional) • GNSS receiver SMA-Female (optional) SIM Card <ul style="list-style-type: none"> • 3.0V / 1.8V • STK 3.1
Sensitivity	<ul style="list-style-type: none"> • LTE B1: -101.5dBm (10M), LTE B2: -101dBm (10M), LTE B3: -101.5dBm (10M), LTE B4: -101dBm (10M), LTE B5: -101dBm (10M), LTE B7: -99.5dBm (10M), LTE B8: -101dBm (10M), LTE B12: -101dBm (10M), LTE B13: -100dBm (10M), LTE B20: -102.5dBm (10M), LTE B28: -102dBm (10M), • WCDMA B1: -110dBm, WCDMA B2: -110dBm, WCDMA B4: -110dBm, WCDMA B5: -110.5dBm, WCDMA B8: -110.5dBm • GSM: -109dBm • DCS: -109dBm
SMS	<ul style="list-style-type: none"> • MO / MT Text and PDU mode
Power supply	5V – 30V DC

Using the modem

Setting up the modem

To set the modem up, follow these steps:

- Eject SIM card holder using the yellow button and pull out the drawer.
- Insert your SIM card into the drawer.
- Verify if the SIM card fits in the drawer properly.
- Insert the drawer into the modem. Connect the antenna to the SMA connector
- Connect the GNSS antenna to SMA connector (GNSS variant only)
- Optionally, the modem can be connected using RS232 or USB interface
- Plug the power supply cable into the power supply input
- Now the modem is ready to work.

Turning the modem off

To turn off the modem, follow these steps:

- It is strongly advised to un-register the modem from the network using *AT+COPS=2* command
- Disconnect the power cable.
- If the modem has internal battery, send the POWER OFF command and wait until all the LEDs turn off.

Installing USB drivers

Before you connect the device to the USB interface, you need to install the drivers. They can be downloaded using the links below:

Windows: [setup.exe](#)

Linux: [README](#)

Checking the communication with the modem

Once the modem is connected you can check RS232 or USB communication between the RB900-Pro and the PC using any Terminal program. Configuration of the DTE (port COM) could be as follows:

- Bits per second: **115200 bps**,
- Data bits: **8**,
- Parity: **None**,
- Stop bits: **1**,
- Flow control: **hardware**.

Using a communication software such as Hyperterminal, enter the **AT** and push 'enter' button. The response of the terminal should be '**OK**' displayed in the Hyperterminal window.

If the connection with the modem cannot be established do the following:

- Check if modem is connected with PC via RS-232 or USB.
- Check the configuration of the COM port.

Examples of AT commands:

- **ATE1** enables modem echo function,
- **AT+CPIN?** shows current status of SIM card
- **AT+CPIN=xxxx** to enter PIN, where 'xxxx' are digitals
- **AT+CSQ** to verify received signal strength
- **ATD<phone_number>**; to initiate a voice call
- **ATH** to hang up a voice call

For further information about AT commands and their usage, refer to [1].

Disabling and enabling echo function

If echo is not displayed when entering AT command, that means:

- The local echo function in software (such as Hyperterminal) is disabled
- The echo function of the modem is disabled

To enable echo function of the modem enter the **ATE1** command.

In Machine to Machine communication it is recommended to disable echo function (type **ATE0**) in order to avoid unnecessary CPU usage.

For further information about **AT** commands and their usage, refer to [1].

Verifying the strength of received signal

RB900-Pro terminal can establish a connection with network if the received signal strength is sufficiently strong. To verify the signal strength and bit error rate, do the following:

using software such as Hyperterminal enter **AT+CSQ**. This command displays the received signal strength indication <rss> and channel bit error rate <ber>. The modem answers as follows:

```
+CSQ: <rss>,<ber>
OK
```

<parameter>	Description
<rss>	0 through 31 - covers the range of -113 dbm (or less) to -51dbm (or greater)
<ber>	Channel bit error rate (in percent) 0-7 RXQUAL values in the GSM 05.08 table 99 Unknown or not detectable

For further information about **AT** commands and their usage, refer to [1].

PIN code status

To check the PIN code status enter **AT+CPIN?** Command.

The table below shows the relevant main responses of the modem:

Answer	Description
+CPIN: SIM PIN	PIN code has not been entered
+CPIN: READY	PIN code has been entered correctly

For further information about **AT** commands and their usage, refer to [1].

Network registration

GSM network registration

To check *GSM* network registration status enter **AT+CREG?** into the software (for instance Hyperterminal). The modem will answer in following format:

+CREG: <n>,<stat>[,<lac>,<ci>]

OK

The following table shows the **+CREG** parameters:

<parameter>	Description
<n>	0 Disables the network registration unsolicited result code. 1 Enables the network registration unsolicited result code +CREG: <stat>. 2 Enables the network registration and location information in unsolicited reports and Read command +CREG:<stat>[,<lac>,<ci>]. The <u>default</u> is 0 .
<stat>	0 Not registered, and the ME is not currently searching for a new operator to which to register. 1 Registered, home network. 2 Not registered, but the ME is currently searching for a new operator to which to register. 3 Registration denied.* 4 Unknown. 5 Registered, roaming.
<lac>	Two-byte location area code in hexadecimal format
<ci>	Two-byte cell ID in hexadecimal format.

*To manage connecting to a network, the SIM card inserted into the modem must be valid. For further information about **AT** commands and their usage, refer to [1].

Checking the communication with GNSS

To activate and check the GNSS position send below AT commands to the modem:

GNSS activation:

```
AT+QGPS=1
```

Obtaining positioning information:

```
AT+QGPSLOC?
```

You can optionally enable e.g. acquisition of NMEA output type GGA sentences using:

```
AT+QGPSCFG="nmeasrc",1
```

Then you can obtain GGA sentence by sending:

```
AT+QGPSTNMEA="GGA"
```

You can find the details in GNSS AT Commands Manual.

AT commands summary

As a conclusion, the table below shows the most common and useful AT commands. For more AT commands refer to [1].

Action	Syntax	Response	Comments
Echo enable	ATE1	OK	Typed text is seen.
Echo disable	ATE0	OK	Typed text is not seen.
Voice call	ATD<phoneNo>; Remember of ';'!	OK	Call initiated.
		NO CARRIER/BUSY/NO ANSWER	Connection failure.
		+CME ERROR: <err>	General error*
		OPERATION NOT ALLOWED	Security reason (such as SIM card not inserted)
		UNKNOWN CALLING ERROR	Unknown reason
Hung up call	ATH	NO CARRIER	Connection is hanged up.
Receiving call	ATA	OK	Call is answered.
Communication loss		NO CARRIER	
Enter PIN code	AT+CPIN=[<puk> or <pin>], [<newpin>]	OK	Set PIN or PUK or new PIN code.*
		+CME ERROR: <err>	General error*
Check PIN code status	AT+CPIN?	+CPIN: <code>	Returns status of PIN.
		OK	e.g. READY or SIM PIN
		+CME ERROR: <err>	General error*

*Refer to [1].

QuecOpen™ (Linux)

Quectel QuecOpen™ is an open embedded platform that is built on the Linux system. It is designed to simplify the development for IoT (Internet of Things) applications. A description of the platform can be found in this document: [QuecOpen Linux.pdf](#)

Troubleshooting

No connection/communication with the modem

If there is no communication with the modem do the following steps:

- Check all external connections of the modem (RS-232 or USB, power supply)
- Verify if the power supply is correct (see **Power supply**)
- Check if the COM port is correctly parametrized
- Check if the program used for communication works properly and if there is no other program interfering. If yes, close the interfering program.

Receiving ERROR message

Modem answers **ERROR** on AT command in following cases:

- Syntax of typed AT command is incorrect – check the command syntax in [1]
- Parameters of typed AT command are incorrect – type **AT+CME=1** for enabling a description of the error that occurred. The response now will be in this format:
ERROR
+CME ERROR: <err>
where <err> is a description of the error that occurred
- Refer to [1] for further details about the occurred error

Receiving NO CARRIER message

There are some common cases when modem answers **NO CARRIER**:

- If data/voice/fax connection cannot be established
- Right after hanging up the data/voice/fax connection
- If there is no connection with network – check antenna and registration status (see Network registration)
- If there is no power supply (see Power supply)

If the modem answers **NO CARRIER** in some cases, you can have an extended error code using **AT+CEER**. The table below shows some of codes which can appear.

Error code	Description
1	Unassigned or unallocated number
3	No route to destination
6	Channel unacceptable
8	Operator determined barring
16	Normal call clearing
17	User busy
18	No user responding
19	User alerting, no answer
21	Call rejected
22	Number changed
27	Destination out of order
28	Invalid number format (incomplete number)
34	No circuit/channel available
38	Network out of order
41	Temporary failure

For further information about **AT** commands and their usage, refer to [1].

Technical specification

Mechanical specification

Max. dimensions	72 x 53.5 x 26 mm (w/o connectors) 83 x 53.5 x 26 mm (w/ connectors)
Weight	≈ 89 g
Volume	100 cm ³ (w/o connectors)
Waterproof class	IP31

Housing diagram

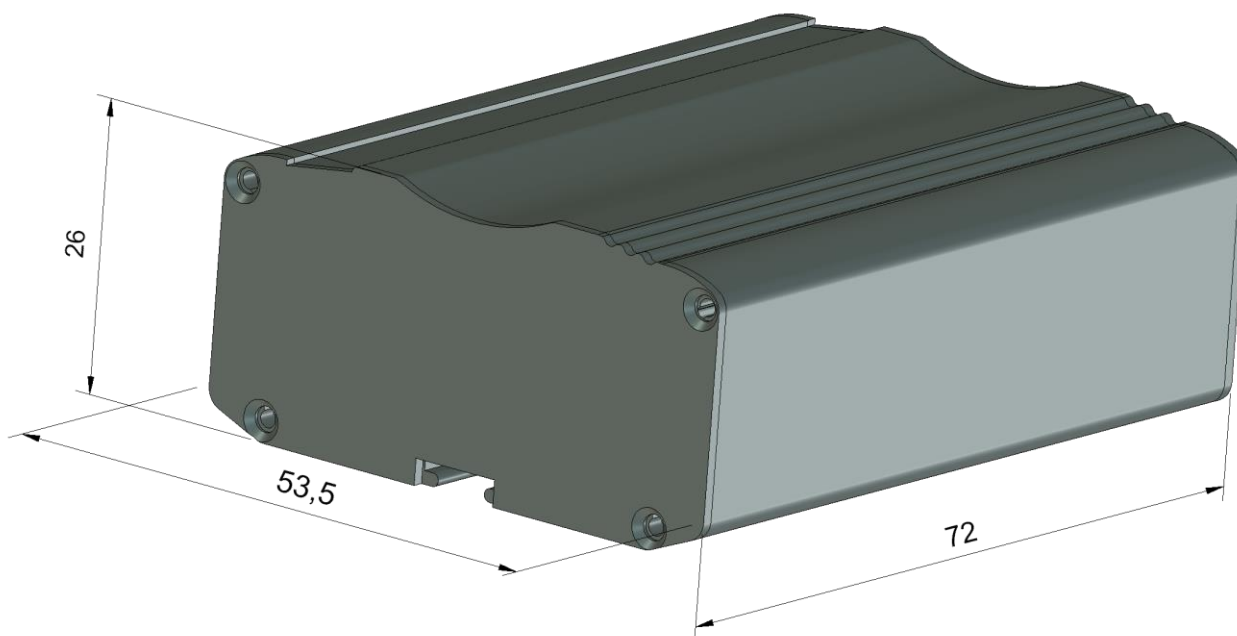

Electrical specifications

Power supply

- Nominal voltage range: 5..30 V, 10%
- Maximum continuous (average) supply power: 2.5 W
- Maximum continuous (average) supply current: 200 mA at 12V

RF specifications

3GPP Band	Transmit	Receive	Unit
B1	1920~1980	2110~2170	MHz
B2 (1900)	1850~1910	1930~1990	MHz
B3 (1800)	1710~1785	1805~1880	MHz
B4	1710~1755	2110~2155	MHz
B5 (850)	824~849	869~894	MHz
B7	2500~2570	2620~2690	MHz
B8 (900)	880~915	925~960	MHz
B12	699~716	729~746	MHz
B13	777~787	746~756	MHz
B18	815~830	860~875	MHz
B19	830~845	875~890	MHz
B20	832~862	791~821	MHz
B26	814~849	859~894	MHz
B28	703~748	758~803	MHz
B40	2300~2400	2300~2400	MHz
B41	2555~2655	2555~2655	MHz

External antennas

The external GSM antenna is connected to the modem via an SMA connector. The antenna must have parameters listed below in the table.

Antenna frequency range	LTE (699-960MHz / 1710-2690MHz)
Impedance	50 Ω
DC impedance	0 Ω
Gain	0 dBi w/o cable; 2dBi w/ cable
VSWR (with cable)	-10 dB

The choice of antenna for the modem should best fit the environment it is used in. When the modem is placed in a room or somewhere where the range of networks signal is too low, the outdoor or specific indoor antenna should be used to boost it.

Environmental specification

The table below gives the environmental operating conditions of the RB900-Pro terminal.

Attention!

Exceeding the values may result in permanent damage to the module.

Parameter	Conditions	Min	Max	Unit
Ambient Operating Temperature		-20	60	°C
Storage Temperature		-40	85	°C
ESD	At antenna connector Contact Air At interface connector		± 6 ± 15 ± 1	KV
Humidity		5	85	%

Safety recommendations

General Safety

Please follow safety regulations regarding the use of radio equipment due to the possibility of radio frequency interference. Please read the advice carefully.

Switch **off** GSM terminal when:

- in an aircraft – using cellular telephones in aircraft may endanger the operation of the aircraft; it is illegal
- at a refuelling point
- in any area with a potentially explosive atmosphere which could cause an explosion or fire
- in hospitals and any other places where medical equipment is in use

Respect restrictions on the use of radio equipment in any area or place where it is signed that using cellular telephones is forbidden or dangerous.

Using the GSM modem close to other electronic equipment may also cause interference if the equipment is inadequately protected. It may lead to damage or failure of GSM modem or the other equipment.

Care and Maintenance

The RB900-Pro terminal is an electronic product that should be treated with care. Please follow the suggestions below to ensure your modem has a long life.

- Do not expose the RB900-Pro to any extreme circumstances like high temperature or high humidity
- Do not keep modem in dirty and dust places
- Do not dismantle the RB900-Pro modem
- Do not expose the modem to any water, rain or steam
- Do not drop, shake or knock your modem
- Do not place your modem close to magnetic devices – credit cards, etc
- Use of third party equipment or accessories, not made or authorized by Elproma Elektronika Sp. z o.o. may invalidate the warranty of modem and/or cause failure or permanent damage to the modem
- Do not expose the modem to children under 3 years

Responsibility

The modem is your responsibility. Please treat it with care, and respect local regulations. This is not a toy – keep it out of the reach of children.

Try to use security features (PIN etc.) to block unauthorized use or theft.

Conformity Assessment Issues

The RB900-Pro has been assessed in order to satisfy the essential requirements of the RED 2014/53/EU to demonstrate the conformity against the harmonised standards with the final involvement of a Notified Body.



List of Acronyms

ACM	Accumulated Call Meter
ASCII	American Standard Code for Information Interchange
AT	Attention commands
CB	Cell Broadcast
CBS	Cell Broadcasting Service
CCM	Call Control Meter
CLIP	Calling Line Identification Presentation
CLIR	Calling Line Identification Restriction
CMOS	Complementary Metal-Oxide Semiconductor
CR	Carriage Return
CSD	Circuit Switched Data
CTS	Clear To Send
DAI	Digital Audio Interface
DCD	Data Carrier Detected
DCE	Data Communications Equipment
DRX	Data Receive
DSR	Data Set Ready
DTA	Data Terminal Adaptor
DTE	Data Terminal Equipment
DTMF	Dual Tone Multi Frequency
DTR	Data Terminal Ready
EMC	Electromagnetic Compatibility
ETSI	European Telecommunications Equipment Institute
FTA	Full Type Approval (ETSI)
GPRS	General Radio Packet Service
GSM	Global System for Mobile communication
HF	Hands Free
IMEI	International Mobile Equipment Identity
IMSI	International Mobile Subscriber Identity
IRA	Internationale Reference Alphabet
ITU	International Telecommunications Union
IWF	Inter-Working Function
LCD	Liquid Crystal Display
LED	Light Emitting Diode
LF	Linefeed
ME	Mobile Equipment
MMI	Man Machine Interface
MO	Mobile Originated
MS	Mobile Station
MT	Mobile Terminated
OEM	Other Equipment Manufacturer
PB	Phone Book
PDU	Protocol Data Unit
PH	Packet Handler
PIN	Personal Identity Number
PLMN	Public Land Mobile Network
PUCT	Price per Unit Currency Table

PUK	PIN Unblocking Code
RACH	Random Access Channel
RLP	Radio Link Protocol
RMS	Root Mean Square
RTS	Ready To Send
RI	Ring Indicator
SAR	Specific Absorption Rate (e.g. of the body of a person in an electromagnetic field)
SCA	Service Center Address
SIM	Subscriber Identity Module
SMD	Surface Mounted Device
SMS	Short Message Service
SMSC	Short Message Service Center
SPI	Serial Protocol Interface
SS	Supplementary Service
TIA	Telecommunications Industry Association
UDUB	User Determined User Busy
USSD	Unstructured Supplementary Service Data

On-line support

Elproma provides a range on on-line support which includes:

- the latest version of this document
- the latest drivers for RB900-Pro
- technical support

This information can be found on our web sites at www.teleorigin.com

For further information you can contact us at:

email: info@elpromaelectronics.com

tel.: +48 (22) 751 76 80

fax.: +48 (22) 751 76 81

TELEORIGIN
UNIQUE TECHNOLOGY FOR TELEMETRY

THANK YOU